



## **RE-designing Access to Cultural Heritage for a wider participation in preservation, (re-)use and management of European Culture**

This project has received funding from the European Union's Horizon 2020 research and innovation programme under grant agreement no 769827.

<b>Deliverable number</b>	D4.1
<b>Title</b>	Workshops Criteria and Planning

<b>Due date</b>	Month 9
<b>Actual date of delivery to EC</b>	10 November 2018

### **Project Coordinator:**

Coventry University

Professor Neil Forbes

Priority Street, Coventry CV1 5FB, United Kingdom

+44(0)797 498 4084

E-mail: [n.forbes@coventry.ac.uk](mailto:n.forbes@coventry.ac.uk)

Project website address: <http://www.reach-culture.eu>



## Context:

<b>Partner responsible for deliver</b>	SPK
<b>Deliverable author(s)</b>	Friederike Berlekamp, Stefan Rohde-Enslin (both SPK)
<b>Deliverable version number</b>	1.0

<b>Dissemination Level</b>	<b>Public</b>
----------------------------	---------------

## History:

<b>Change lo</b>			
<b>Version</b>	<b>Date</b>	<b>Author</b>	<b>Reason for change</b>
0.1	20/07/2018	Friederike Berlekamp, Stefan Rohde-Enslin	First draft
0.2	31/07/2018	Friederike Berlekamp	Revisions after Project Manager feedback
0.3	04/09/2018	Friederike Berlekamp	Revisions after Project Manager feedback
1.0	24/10/2018	Friederike Berlekamp, Stefan Rohde-Enslin	Revisions following peer review feedback from CUNI and UGR

<b>Release approval</b>			
<b>Version</b>	<b>Date</b>	<b>Name &amp; organisation</b>	<b>Role</b>
1.0	10/11/2018	Tim Hammerton, COVUNI	Project Manager



## TABLE OF CONTENTS

<b>1. EXECUTIVE SUMMARY .....</b>	<b>4</b>
<b>2. INTRODUCTION.....</b>	<b>5</b>
<b>2.1 STRUCTURE OF THE DOCUMENT .....</b>	<b>5</b>
<b>2.2 BACKGROUND .....</b>	<b>6</b>
<b>2.3 ROLE OF THIS DELIVERABLE IN THE PROJECT .....</b>	<b>6</b>
<b>3. GUIDELINES FOR THE WORKSHOPS .....</b>	<b>8</b>
<b>3.1 OBJECTIVES AND OUTCOME .....</b>	<b>8</b>
<b>3.2 TOPICS, VENUES AND DATES .....</b>	<b>8</b>
<b>3.3 PARTICIPANTS.....</b>	<b>10</b>
<b>3.4 ORGANISATION .....</b>	<b>11</b>
<b>3.5 OPERATION .....</b>	<b>11</b>
<b>3.5.1 PREPARATION .....</b>	<b>12</b>
<b>3.5.2 FORMATS .....</b>	<b>13</b>
<b>3.5.3 STRUCTURE .....</b>	<b>14</b>
<b>3.5.4 INSTRUMENTS FOR THE SUSTAINABILITY OF THE WORKSHOPS.....</b>	<b>15</b>
<b>3.5.5 WORKSHOP DATA.....</b>	<b>15</b>
<b>4. ASSESSMENT CRITERIA.....</b>	<b>16</b>
<b>5. RESULTS AND IMPACT .....</b>	<b>17</b>
<b>6. CONCLUSION.....</b>	<b>18</b>
<b>APPENDIX: DEFINITIONS OF TERMS AND ABBREVIATIONS.....</b>	<b>19</b>



## 1. EXECUTIVE SUMMARY

This deliverable corresponds to the REACH Description of Activity (DoA) and the specified activity described in Work Package 4 - *Workshops & conferences*. In particular, it fulfils the requirements of task T4.1 - *Criteria and Planning* - and outlines the framework for four international interdisciplinary thematic workshops and defines the terms of reference and developing assessment criteria for the workshops which will serve as a basis for the evaluation of the events.

The workshops will provide a forum, firstly, to debate participatory activities in the field of culture and cultural heritage (CH) in respect to their objectives, framework conditions and impacts, to exchange experience and best practice examples and to identify possibilities, difficulties, limits and desiderata. Secondly, concepts of participatory work in the field of CH, its areas of activities, approaches, methodologies and voids, will be critically discussed and may be further developed in a multi-perspective manner. In this way, emerging and required strategies and procedures for the implementation of participatory work may be identified. On this practical and theoretical basis, participatory initiatives will be enhanced, mutual understanding between different societal sectors/stakeholders will be improved and advocacy papers for participatory work will be formulated.

The aim of this document is to give REACH partners and Associate partners guidelines for the organisation and implementation of the workshops. It illustrates the main components of the planning of the workshops and their evaluation:

- dates and venues of the workshops
- objectives and outcomes of the workshops
- participants
- organisation and operation of the workshops
- assessment criteria.

In particular, it explains criteria for the balanced selection of the relevant participants, states different formats and defines aspects for the evaluation of the individual events as well as for the final considerations. Furthermore, it takes into account connections to previous and parallel projects.

The realisation of the workshops and their outcomes will permeate all aspects of the REACH project's work by:

- validating the analytical models of participatory activities
- stimulating the implementation of the pilots
- gathering data to populate the social platform
- enhancing the discussion on sustainability and resilience of CH.



## 2. INTRODUCTION

Exchange, debate, collaboration and co-creation play an important role in “unlock[ing] the potential of people.” The thematic workshops provide a suitable framework for such interactions in order to bring together as diverse stakeholders as possible, to learn from each other through personal contact. The joint elaborations and debates foster the objectives of the REACH project set out in the Description of Activity (DoA) (p. 3) by offering space for a creative and multi-perspective discussion of participatory work in the field of culture and cultural heritage (CH).

Four international thematic workshops will take place during the term of the REACH project with the aim of giving interested groups the opportunity to present participatory initiatives, to exchange their intentions, expectations and experience and to familiarise participants with specific interests and requirements. At the workshops, stakeholders will have the opportunity to analyse possibilities and necessary framework conditions, as well as difficulties, limits and gaps of participatory work from diverse perspectives and to discuss the contribution of participatory approaches in the field of cultural heritage to social and cultural innovation in Europe. Particular focus will be placed on identifying the determinants for the implementation of participatory activities. Further attention will be paid to proving whether these decisive factors can be universalised, both in the particular areas of the individual workshop/project topics and at a general level in order to enable a derivation of theoretical frameworks of participatory activities. On this basis, both specific and generalised advocacy papers can be formulated and agreed collectively.

Each workshop will focus on a particular topic. The main areas to be addressed will be management of CH, creativity and entrepreneurship ((re-)use of CH), territorial cohesion (preservation of CH) and resilient CH at the levels of minority heritage, institutional heritage, rural heritage and small town heritage respectively, as explored within the project’s four pilots.

This deliverable, D4.1, describes the framework for the international workshops. It serves as a guideline for the implementation of the events organised by the REACH partners (SPK, COVUNI, UGR and CUNI, respectively) and, where appropriate, their associated partners. Additionally, it provides reference points for the evaluation of the workshops, which will be conducted by WP4 - *Workshops & conferences* - and presented in the deliverable D4.2 – *Workshop results and lessons learnt*. Furthermore, it shows the interconnections of the workshop and the other work packages.

### 2.1 STRUCTURE OF THE DOCUMENT

Including the Executive Summary there are six chapters within this deliverable.

This second chapter introduces the topic of this deliverable and explains the background. It shows the connections to the other work packages and describes the role of the deliverable in the project.

The third chapter deals with the framework of the workshops. It contains the dates, the objectives, the participants, the organisation, the operation and the follow-up phase.

The fourth chapter defines the criteria on the basis of which the workshops are to be evaluated. It outlines the outcome of the workshops in relation to other REACH work packages.

The fifth chapter considers potential results and impact as a result of the workshops.

The final chapter provides a conclusion.



## 2.2 BACKGROUND

The objective of the REACH project is to develop a social platform that supports and coordinates participatory initiatives in the area of CH and offers a forum for debate, project development and collaboration. It may serve as a basis for further thinking on the functioning of participatory work and for reflecting on research issues, methods and gaps. The thematic workshops will provide an opportunity to enrich the discussion, expand knowledge and open up new perspectives through personal encounters with a broad spectrum of stakeholders and potential partners. They will include presentations of current or completed projects and their best practices, as well as joint work focussing on specific topics of CH in discussion rounds and collaborative sessions. They will be complementary to the use of the social platform [www.open-heritage.eu](http://www.open-heritage.eu) and social media. Together with the pilots (WP5), data collection (WP6), development of analytical models of participatory activities (WP3) and discussion on the sustainability of the social platform, elaborated during REACH, and resilience of CH (WP7), the workshops will support the objectives of the REACH project to strengthen CH's role in social integration in Europe, in particular through the participation of European citizens.

REACH can draw on collaboration experience and contacts from previous projects such as MEMOLA, RICHES, E-SPACE and the sister project Culture Labs, as well as its Associate partners. It will, therefore, use these examples, both in the planning of the workshops and the setting of topics, as well as with regard to the selection of the participants and the dissemination of the workshop results.

## 2.3 ROLE OF THIS DELIVERABLE IN THE PROJECT

This deliverable has been produced within the framework of WP 4 - *Workshops & Conferences* under the direction of SPK, the Work Package 4 Leader, and fulfils the task T4.1 - *Criteria and Planning*. It uses the Description of Activity (DoA) and the deliverables D1.1 – *Quality Plan*, D2.1 – *Project website, internal communication tools, dissemination plan and promotional material*, D2.2 – *Terms of reference for community building and stakeholder consultation* and D6.1 - *Data Management Plan* as references. The outcomes of the workshops will be presented in the deliverable D4.2 – *Workshop results and lessons learnt* expected after the first three workshops will have taken place, providing the summarised report on the thematic workshops in Berlin, Coventry and Granada. The results of the workshop in Prague will be presented in the deliverable D4.3 - *Workshop on Resilient CH: report* - which includes analyses of best practices for achieving CH's resilience and proposals for formulating the final version of the "REACH proposal for a resilient European CH."

The workshops will make a comprehensive contribution to the REACH project by enabling representatives of different social sectors or interested groups to exchange knowledge and experience in direct contact and to discuss the possibilities, problems, limitations and impacts of participatory initiatives. On this practical basis, generalised assumptions and deductions can be proofed, theoretical frameworks and analytical models for participatory approaches can be derived and advocacy papers can be developed.

The workshops themselves and their planning and evaluation are directly linked to work packages 2 *Dissemination and communication*, 3 *Critical review and model building*, 5 *Participatory pilots*, 6 *Data collection and measurement* and 7 *Sustainability and resilience*.

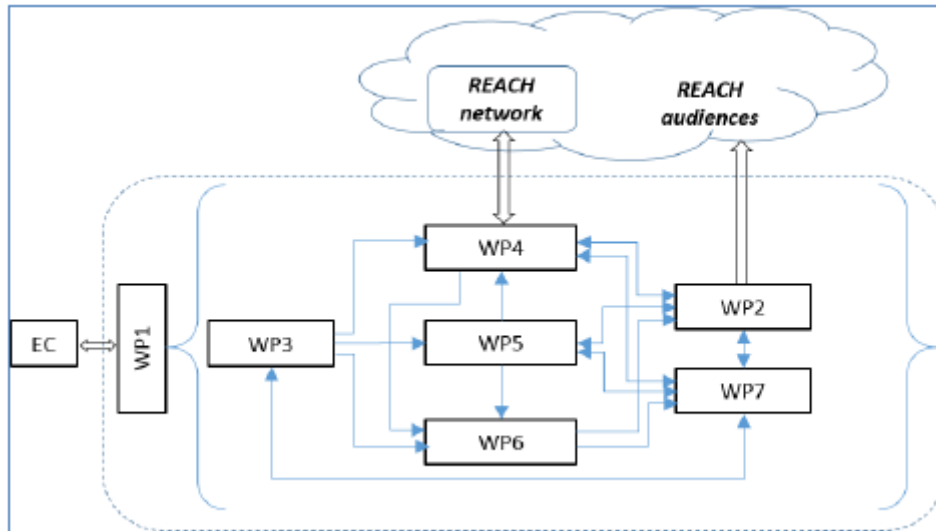

(D2.2 – Terms of reference for community building and stakeholder consultation as reference, p. 10)

This deliverable offers guidelines for conducting the workshops. It outlines the main characteristics of the workshops, describes the objectives and requirements for their organisation and implementation and defines the evaluation criteria for all workshops. The diversity of the conditions of each event is taken into account. Providing the workshop guidelines, this document has an important function, ensuring the comparability of the workshops and their results and, therefore, their joint evaluation.



### **3. GUIDELINES FOR THE WORKSHOPS**

#### **3.1 OBJECTIVES AND OUTCOME**

The workshops will be an important interactive and collaborative opportunity for stakeholders and researchers to meet, to present activities and to glean and debate approaches, best practices, lessons learnt, results and impacts of participatory activities in a broader, yet more focused context. They will strengthen the relationships between stakeholders; potentially leading to the establishment of new networks as a result of these personal encounters.

Besides the personal exchange of knowledge and experience, the workshops aim to review the theoretical considerations on the basis of practical experience in order to serve the implementation of participatory initiatives, the design of the appropriated framework conditions, as well as future research into participation. Each workshop will seek to formulate advocacy papers. Based on the results of practical experience and theoretical conclusions, these documents will offer recommendations on participatory approaches in the areas of preservation, (re-)use and management of cultural heritage.

As the workshops are designed to be forums for creativity, they will try to avoid becoming mini-conferences containing numerous presentation, instead allowing discussions and collaborations on cross-cutting issues in the areas of CH at local and international level, themes that are likely to be broader than the project's four specific pilots' activities.

As discussed previously, the workshops will operate within the scope of the wider REACH project, contributing towards the development of the [www.open-heritage.eu](http://www.open-heritage.eu) social platform, considering pilots' activities and identifying examples of best practice. In addition, the workshops will provide material for the final discussion on the meaning and effects of participatory approaches and their sustainability, and the resilience of the CH milieu and therefore contribute towards "The REACH proposal for a resilient European CH."

#### **3.2 TOPICS, VENUES AND DATES**

Four thematic workshops will take place during the REACH project, between months 13 and 27, examining the value and potential of participatory approaches to the management, (re-)use, and preservation of CH, both in terms of research advancement and social innovation. Each workshop is designed to explore a particular theme:

1. *Participatory approaches for CH management*, to be organised by Stiftung Preußischer Kulturbesitz and held in November 2018 in Berlin

In the field of CH-management, this workshop will focus on improving the quality of services provided by CH-institutions, the commitment of users, cost reduction in the provision of services and its effective implementation through participative approaches. The event will benefit from the large network of CH-institutions with which SPK is connected. The workshop will draw on the experience and lessons learnt from the participatory activities of the RICHES project, in which SPK led the research on changes in the CH-institutions. It will be primarily aimed at cultural institutions and representatives of the public administration. RICHES project: <http://riches-project.eu/>





2. *Participatory approaches for creativity and entrepreneurship*, to be organised by Coventry University and held in March 2019 in Coventry

In the field of (re-)use of CH, this workshop will examine the impact on public and private investment in culture. The workshop will deal with economic growth and new employment opportunities arising from the use and re-use of CH and the importance of considering issues of intellectual property. It will also focus on the possibilities of participatory approaches to facilitate and support these developments. This event will draw on the experience and lessons learnt from the participatory activities of the E-SPACE project coordinated by COVUNI, which will be adapted to the framework of the REACH project. The event will be primarily aimed at the creative industries, innovative tourism organisations and local development agencies. E-SPACE project: <http://www.europeana-space.eu/>

3. *Participatory approaches for territorial cohesion*, to be organised by Universidad de Granada and will most likely be held in October 2019 in Granada

In the field of CH-preservation, this workshop will debate territorial cohesion and the involvement of rural communities. The meeting will be based on the experience and lessons learnt from the participatory activities of the MEMOLA project coordinated by the UGR. The event will be primarily aimed at local governments, local authorities and citizens' organisations. MEMOLA project: <http://memolaproject.eu/>

4. *Resilient CH*, to be organised by Univerzita Karlova and most likely held in April 2020 in Prague.

This final workshop will focus on prior discussions and the results on the resilience of CH collected by the partners since the start of the REACH project. The aim of this meeting is to elaborate the REACH proposal for resilient CH. The debate will be additionally prepared by a series of local workshops, which are organised together with the KREAS research team in a research project, and of international workshops. Relevant stakeholders and associated partners will be invited to discuss the experience gained from the REACH project.

As the project progresses, other work packages will be able to provide greater input into the discussion topics of each workshop, this will especially be the case with the final workshop in Prague. The outputs of the workshop will also be fed into other aspects of the project's work.

In addition to the specific topics of each workshop, further debates may include the following aspects:

- the role of civil society in cooperation with CH experts
- the interaction of cultural heritage with education and democratic processes
- partnerships between the cultural and private sectors
- broad/balanced involvement of diverse stakeholders in participatory initiatives regarding their specific interests and needs (in the concept of activities and during their execution)
- the impact of broader social participation on better and more sustainable outcomes
- more integrative methods of multidisciplinary research on CH conservation
- the perception and incorporation of gender perspectives in CH.

Further aspects, introduced by the participants, may be considered for the most comprehensive possible discussion on participatory work. They may serve as links between the activities and debates.



By identifying and discussing similarities and differences, both overarching topics and new research directions may be identified. On this basis, innovative methods, tools and skills for the preservation, (re-)use and management of cultural heritage may be provided.

It will not be possible to cover all thematic areas during a workshop, but the interaction of the four workshops will aim at a comprehensive and multi-perspective treatment of participatory work in CH.

### **3.3 PARTICIPANTS**

The REACH project offers an international forum for communication and exchange of participatory approaches in the field of European CH. Therefore, the workshops will be aimed at international audiences, including those from non-EU countries, to ensure linkages between local and international perspectives and debates and to encourage cross-cutting exchange and initiatives.

The workshop will operate on an invitation only basis and will therefore be able to include as diverse a group as possible in order to be able to illuminate and discuss aspects of participatory work from different views and to shape the exchange and cooperative efforts across interests. Participants will be selected according to the specific needs of the aspects under discussion and will include different types of stakeholder, professionals and non-professionals from various regions/countries and from different organisational structures, e.g. consortium members, associated partners, cultural workers, representatives of civil society, administrative staff, politicians and researchers. To ensure a good working atmosphere the number of participants will be limited to 25 people. REACH partners are welcome to provide suggestions to ensure the optimum list of participants, although the organising partner will make the final decisions and issue invitations.

As the REACH project is committed to implementing gender-sensitive approaches, invitations will take into account that they will be gender-balanced and that, where appropriate, the working atmosphere will meet the needs of the participants.

As it is important to have a group of experts involved in the discussion, places are not automatically offered to project partners, although they would be welcome to join the organising partner at the workshop, where they can constructively contribute to the discussion. A number of partners can attend in a non-participatory roles to introduce aspects of the project such as pilots or participatory models or to evaluate results, but would not take up the places of invitees who could add specific considerations to the workshop's discussions. Ideally this number will be kept to a minimum so as not to inhibit discussion, especially if sensitive or private subjects are included. REACH workshops will provide participants with a safe space for open exchange and discussions and no information will be passed on to third parties without the written consent of the data subject.

REACH partners are likely to be present at the final discussions of the workshops to hear a presentation of the practical experience exchanged, theoretical conclusions and areas for development and they may participate in the debate on recommendations for the implementation of participatory initiatives.

Representatives of the EU will also be invited to participate in the discussions and collaborative sessions.



### 3.4 ORGANISATION

The designated host/organising partner will be supported by the WP2 Leader, Promoter, in the dissemination tasks, in particular through the project's website, to promote the events and maximise participation in the preparation, implementation and follow-up phases. At this stage, a page has been created for the Berlin workshop, detailing its objective. It will be updated following its conclusion to detail discussion and results.

<https://www.reach-culture.eu/events/workshops/workshop-on-participatory-approaches-for-cultural-heritage-management>

The other three REACH thematic workshops will also have a page populated on the project's website, as further development takes place.

Each host partner has a budget of 5,000 Euro to cover the organisation of their workshop that includes venue costs, catering, any resources to be used and staffing. Ideally, this budget should also cover the travel costs of key personnel taking part within the workshop.

COVUNI holds the budget to support Associate partners' attendance at project events. An approximate figure of 2,000 Euros can be made available to support for each workshop. Such funding would only be available for participants that have an integral role within the workshop. A maximum of 500 Euro can be paid to an individual, where expense is authorised in advance and on receipt of evidence of reasonable expenses.

### 3.5 OPERATION

The workshops will be international oriented; participants will be invited from different countries. The workshop language will be English.

Each workshop will take place over a two day period, often starting and ending around lunchtime of each day.

The implementation of the workshops will be the responsibility of the institutions listed in chapter 3.2 (1<sup>st</sup> SPK, 2<sup>nd</sup> COVUNI, 3<sup>rd</sup> URG and 4<sup>th</sup> CUNI). An important task for each organisation will be to consider the most appropriate person or team to facilitate the event, to both ensure that conversation flows freely and that each workshop's objective is met.

Each organising/host partner will consider its specific topic and may, if appropriate, include further sub-aspects. Although there may be close thematic links between the workshops and the activities of project pilots, the focus of the meetings will take a different approach. The discussions in the individual workshops are not limited to pilots' scope; the contributions and requirements of other participants, their topics and/or relevant sub-aspects are also taken into account at the programme planning stage.

Each workshop will be different, with its own mission statement and specific workshop plan, but will support the common goal of REACH with its specific presentations and discussions. The structure will be flexible for each workshop, as each partner must respect different framework conditions with regard to the respective thematic, personal and structural particularities. However, all workshops will follow the guidelines described in this deliverable to ensure an evaluation of the four events.



### 3.5.1 PREPARATION

The organisers of the workshops will set a specific date and place for the workshop and inform the REACH partners and relevant parties as soon as possible.

They will set the thematic priorities and decide accordingly who is to be invited as participants (CH professionals, arts practitioners, representatives of interest groups, etc.). Three or four exemplary players/initiatives will be selected to make introductory presentations of their activities/results at the workshop.

Since the duration of the workshop is very short, getting to know each other and the exchange and discussions between participants will begin before the start of the workshops. In this way, the interaction can be constructive, as quickly as possible, and results will be achieved in a short time. For this purpose, an appropriated time before the workshops will take place, introductions to the activities presented and discussed at the workshops will be provided by the representatives of the initiatives, e.g. in the form of a slide presentation, a hand-out or a video. The preparatory material will also contain information about the participants themselves and contact details, subject to individual consent.

The information required for each workshop on the activities and participants will be determined by the organisers. The organisers will prepare a form in order to ensure that the delivered information will be consistent and also will meet the requirements of the specific discussions. They will send it to the participants, both the representatives of the projects being presented and the other participants. This form may include a short biography explaining the relation to CH, areas of interest, contributions/experience, wishes and expectations regarding the issues and sub-items to be dealt with at the workshops, which are proposed by the organisers or the participants, and, if applicable, appropriate bibliographical references. Participants will be invited to state their own priorities. Building on this, the organisers can work out the essential sub-topics and needs for the discussions. This information will help to plan the work meetings in more detail and to broaden the debate on participatory work with cross-cutting approaches and results. In this way, relevant sub-aspects can be included in the more precise programme planning enabling discussions during the workshops to start from an advanced base.

To maximise the activities presented during the workshops, representatives may be asked to prepare posters.

The requirements for their attendance will be explained to the participants when they accept the invitation. All those invited, will be requested to confirm their participation within an appropriated time before the workshop will take place.

The organisers will devise an introductory presentation explaining the work of REACH and its objectives as well as the social platform [www.open-heritage.eu](http://www.open-heritage.eu) and the (topic specific) participatory pilots.



Organisers may draft an advocacy paper on their specific area of participation in CH in advance of the workshops (using a range of sources, including REACH or other relevant project activity). It would be addressed to the stakeholders of the specific sector and provide information on the state of the art of participatory work, list best practices and gaps, and give recommendations for the further development of both participatory activities and its research. This draft will be based on discussions during preparation of the workshops, experience from the pilots and also on the information provided by the participants in advance. The organiser may send it to the participants before the workshops so that its discussion can be more comprehensive and in-depth or use the workshop discussions as a base for writing it. In both cases, it would be circulated for comment and approval before it is finalised and issued, as an output of the project.

Further, the topics and questions that emerge from the preceding exchange may be summarised by the organisers on posters or flipcharts. They can serve as starting points for joint discussions and elaborations. The organisers will choose appropriated formats to discuss their particular aspect of CH (management, creativity and entrepreneurship, territorial cohesion and resilience) and to gather the information on best practices.

### **3.5.2 FORMATS**

In order to obtain a wide variety of approaches to the topics dealt with and lively interactions, different event formats may be used. However, they should be appropriate to the issues to be addressed. Therefore, the workshops will consist partly of a key note, short impulse lectures and/or presentations of initiatives. Interactions, such as hands-on sessions, co-creation exercises and joint discussions, will be another important component, as they will promote direct communication and collaboration between the participants and lead to new ideas and practical impulses for the respective or future activities. The joint exchange and discussions are the focus of the workshops and are therefore granted as much time as possible. The joint elaboration can take various forms, which could include:

#### **1. Joint discussion rounds**

#### **2. Group work**

In order to create a favourable working atmosphere and to develop as wide a repertoire of subjects as possible, the participants may be divided, if appropriate, into smaller groups (6-8 persons). Each group will develop a specific topic and prepare the most important results in the form of a short report for the joint discussion. The records of each group will be noted and presented by designated personnel. These minutes will be relevant for the final discussion and for the advocacy paper, as they reflect the analysis of experience, results and needs as well as the arising problem areas.

#### **3. Invitation of an external guest.**

For further stimulation, e.g. in form of a keynote speech, a person may be engaged who does not belong to the group of participants. This guest will familiarise the participants with additional participatory approaches from neighbouring areas or from the perspective of a certain interest group. Subsequently, their contribution will be drawn from previous debates or be linked to a new aspect of the thematic area, which will be further developed as a result of the new information gained.



Depending on the topic of the respective event and the participants, the organisers will decide which type of interaction and group size is suitable. They will also determine whether different formats will be used during the joint sessions and whether the individual groups will be reassembled.

### 3.5.3 STRUCTURE

#### 1. Welcome and Introduction

- a) The REACH project will be introduced, including a short description of the social platform, its operation and benefits, and the presentation of the pilots with special emphasis on the participatory activities relevant to the workshop topic.
- b) The main topic of the workshop and sub-aspects discussed during the preparatory phase will be outlined.
- c) Participants introducing themselves.
- d) Short introduction of the participatory initiatives presented and first comments, summarising the previous exchange

#### 2. Collaborative session/discussions

During these sessions there will be a concentrated exchange and discussion on the activities presented. In this context, sub-aspects may be taken into special consideration.

#### 3. Feedback session

Even though the individual workshops have their specific orientation and approaches, the reflection on the workshop itself regarding formal characteristics – like its formats and methods used and their appropriateness –, and content-related observations –expectations/experience gained/impacts – will serve to tailor and further elaborate the following events more precisely to the needs of the stakeholders and other interested groups. The evaluation criteria listed in this deliverable, in chapter 4, can be used as a starting point for this discussion.

#### 4. Final discussions and developing of advocacy papers

- a) Discussion on practical experience: i) the initiatives with particular emphasis on the thematic areas/sub-aspects worked on during the sessions and development of the interconnections and overlaps between the activities and ii) the limits and gaps of the approaches shown in the examples.
- b) Discussion on theoretical conclusions: possible generalisation of areas of participatory actions of the presented initiatives and their circumstances.
- c) Reflection on the need for action/research, review of the draft of the advocacy paper with special consideration of the experience exchanged in the workshops and findings worked out with the aim of adopting an advocacy paper. It is likely that the final paper will be written after the conclusion of the workshop (possibly based on the preliminary draft), shared with relevant participants for comment and agreement ahead of finalisation.



### **3.5.4 INSTRUMENTS FOR THE SUSTAINABILITY OF THE WORKSHOPS (FOLLOW-UP PHASE)**

The entire workshops will be documented in text and pictures. The documentation will be reviewed and made available to workshop participants on the REACH project website [www.reach-culture.eu](http://www.reach-culture.eu). After the workshop, the organisers will ensure that a blog entry is created on the REACH website [www.reach-culture.eu](http://www.reach-culture.eu) for each of the initiatives presented (by themselves or by the representatives) and that the activities are included in the database of best practices (WP6) and available on the social platform [www.open-heritage.eu](http://www.open-heritage.eu).

### **3.5.5 WORKSHOP DATA**

REACH takes the General Data Protection Regulation (GDPR) into account. The information shared at the workshops on individuals and initiatives is protected. Nothing will be passed on to third parties unless the personnel concerned have expressly agreed to this in writing, e.g. for publications and other distribution.

As part of the REACH project's Data Management Plan, a new dataset will be recorded for each workshop noting any information acquired and retained in the organisation and hosting of the event, together with the location where any specific data are stored. Host partners will be encouraged to delete any data that is no longer required, after the conclusion of the workshop.



#### **4. ASSESSMENT CRITERIA**

The workshops will be successful if:

- a variety of (cross-cutting) aspects of CH are dealt with from different perspectives
- the diversity of the participants (in terms of gender, field of activities, organisational structures, origin etc.) has been accomplished
- area-specific or/and general possibilities, problems, limits and gaps of participatory activities are identified
- information is discussed that broadly considers different perspectives
- research approaches and methods will be reviewed and developed
- advocacy papers are discussed and adopted in agreement (over the following weeks)
- experience and gathering best practice are shared for the social platform [www.open-heritage.eu](http://www.open-heritage.eu) (WP6)
- interaction during the events (exchange between the participants) is vivid and constructive, with people/institutions having been introduced to and having a broader and/or deeper understanding of other ongoing activities.





## 5. RESULTS AND IMPACT

This deliverable provides guidelines for the implementation of the four thematic workshops, in which practical experience with participatory activities and theoretical derivations are discussed.

The workshops will play an important role for the REACH project as direct contact and collaborative sessions have a stimulating effect on its implementation. These events aim to expand the exchange of practices, considering possibilities, difficulties, potentials, limits and desiderata of participatory work. On this basis, the planning and conduct of participatory activities may be supported and the participation of societal sectors in the field of culture and cultural heritage may be strengthened. Furthermore, advocacy papers may be discussed and adopted for specific areas (management, preservation and (re-)use) as well as in other fields.

The workshops will support diverse work packages of REACH:

*WP2 - Dissemination and communication:* Each workshop will support dissemination by informing participating stakeholders and further interested groups about the REACH project, as well as about the participatory initiatives presented at these meetings and the discussions and sessions. The workshops and their outcomes will be presented and disseminated in a variety of innovative ways. This may include both analogue and digital media, such as blogs, tweets, articles in relevant journals, video clips, SoundBits etc.

*WP3 – Critical review and model building:* The examples of participatory activity identified within REACH workshops could be incorporated into the models developed within WP3 and be included in considerations of impact.

*WP4 - Workshops & Conferences:* The knowledge gained and lessons learnt in each workshop will contribute to the development of future project workshops both in terms of composition and structure, as well as potential outcomes. The findings of the workshops could be presented during the project's final conference in Rome.

*WP5 - Participatory pilots:* Pilots may benefit from the personal encounters at the workshops by meeting other relevant (local and/or international) stakeholders and networking with them. The information exchanged at the workshops will enable participants to critically review, evaluate and, if necessary, modify or expand their participatory initiatives. This knowledge may be used in the pilots and other initiatives, enriching and shaping them.

*WP6 - Data collection and measurement:* The information exchanged during the workshops and the results of the discussions will flow into the data gathering and be available on the social platform [www.open-heritage.eu](http://www.open-heritage.eu). They will remain accessible and may be considered and used in further activities. Datasets will also be created for each workshop within the Data Management Plan.

*WP7 - Sustainability and resilience:* The workshops, with their interactive debates and collaborative sessions will make an important contribution to this discussion, especially the fourth workshop in Prague, where the preliminary results of the local and international workshops, the social platform and the pilots will be discussed before the completion of "The REACH proposal for a resilient European CH."



## 6. CONCLUSION

Communication, exchange and cooperation play an important role in the progress of participatory work. REACH workshops will strengthen these initiatives and will also support critical reflections on citizens' participation in the field of culture and cultural heritage, providing a safe space for open multi-perspective debates and collaboration. The exchange of lessons learnt and best practices will be the focus of the events, not only to incorporate the information gained into the data collection, but also to learn from each other, to encourage participants' scrutiny of their own participatory initiatives and the engagement in CH and to consider ways to improve them.

The workshops aim to cover as wide a spectrum of CH topics and sub-aspects as possible including management, creativity and entrepreneurship, territorial cohesion and resilient CH. The starting point will be the themes proposed in the DoA, but topics will also incorporate the needs and interests of the participants and practitioners, therefore identifying areas of overlap, potential, limits and needs for effective participatory work. In order to achieve a broad, lively and constructive discussion, participants will be representatives of a wide range of stakeholders, invited specifically for their expertise and knowledge and can contribute to the definition of next steps, considering scientific perspectives, to sound out the benefits and needs of participatory work and to formulate advocacy papers.

It is important that each REACH workshop has a clear objective to be able to set a focussed agenda, invite relevant participants and be aware of its end goals, albeit allowing flexibility for discussion to lead to new and varied outcomes. This deliverable has set out a structure for each organising partner to work within, but one that allows a tailored approach that considers the specific thematic sector to maximise discussion and results.



## **APPENDIX: DEFINITIONS OF TERMS AND ABBREVIATIONS**

CH – Cultural Heritage

DoA – Description of Activity

E-SPACE –Europeana Space

KREAS – Kreativita a Adaptabilita Jako Předpoklad Úspěchu Evropy v Propojeném Světě („Creativity and Adaptability as Conditions of the Success of Europe in an Interrelated World“)

MEMOLA – Mediterranean Mountain Landscapes

RICHES – Renewal, Innovation and Change: Heritage and European Society

WP – Work Package

COVUNI – Coventry University

PROMOTER – Promoter SRL

SPK – STIFTUNG Preußischer Kulturbesitz

UGR – Universidad de Granada

CUNI – Univerzita Karlova